

4 3 2 1

B

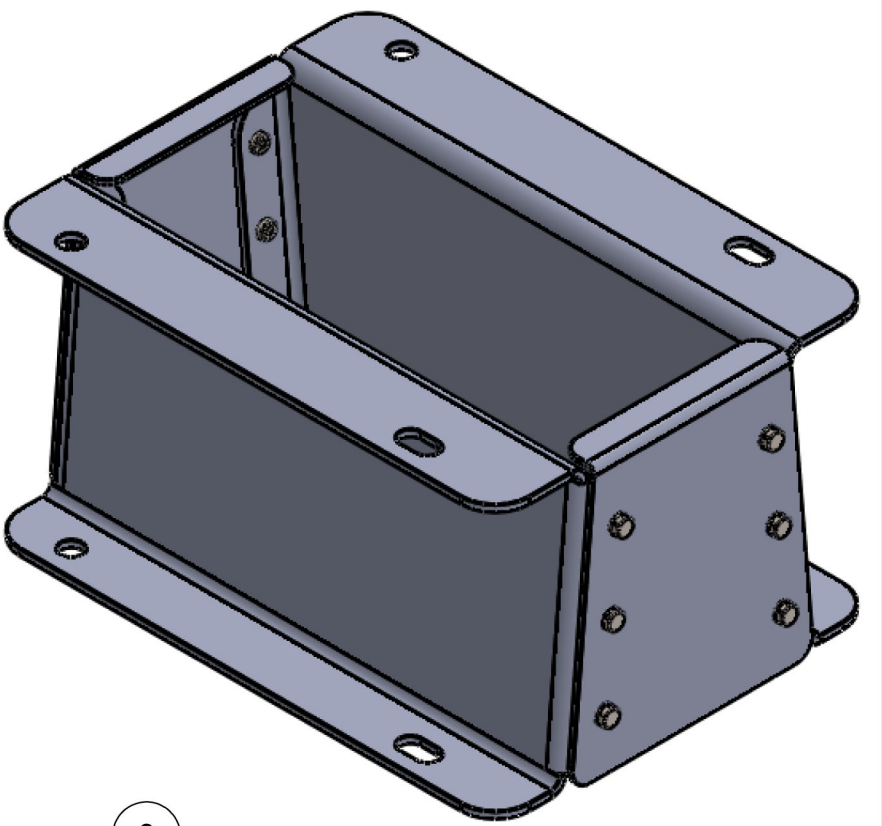
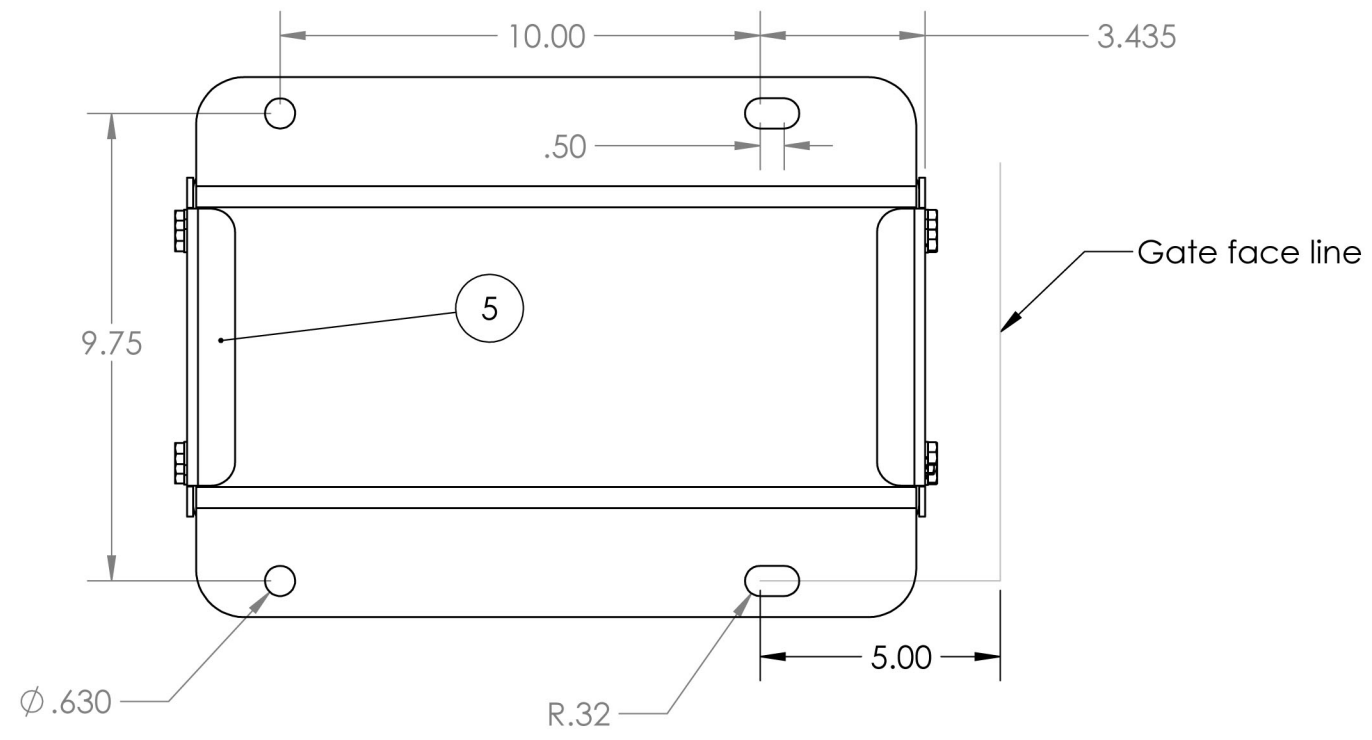

B

A

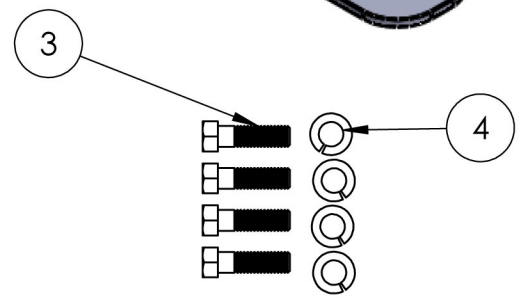
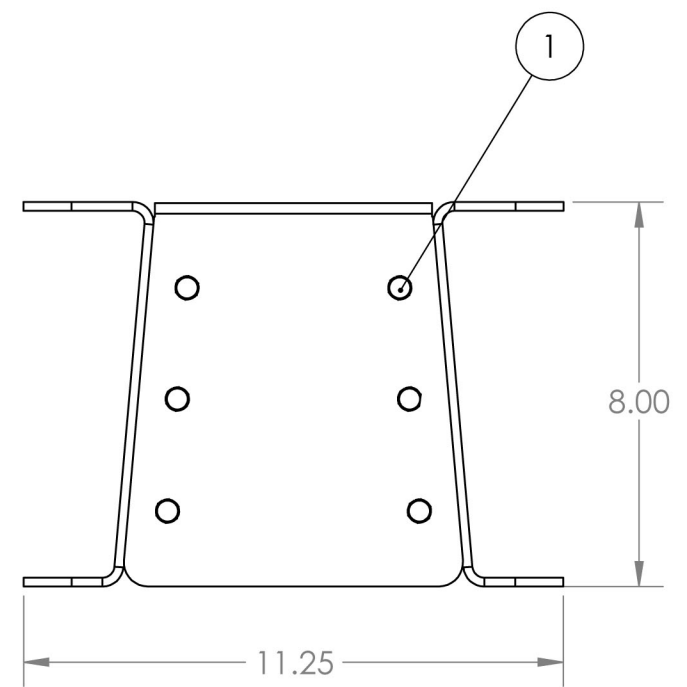
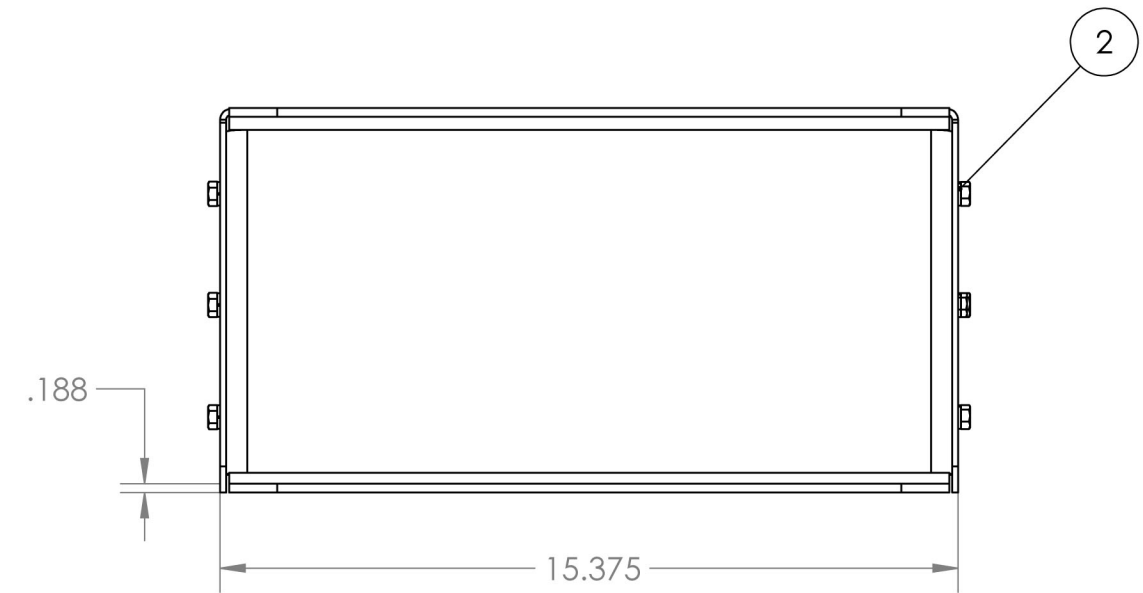

- 1. 1/4-20 X 1/2" long Hex Bolts (X12)
- 2. 1/4" Split Lock Washer (X12)
- 3. 1/2-13 X 1.5" Long Hex Bolt(X4)
- 4. 1/2-13 Hex Nut (X4)

A

4 3 2 1

TITLE:		
SL-100 Pedestal		
MATERIAL	SIZE	DWG. NO.
CR	B	100-PDT
	SCALE: 1:4	REV
	WEIGHT:	1
		SHEET 1 OF 1

2

1

B

B

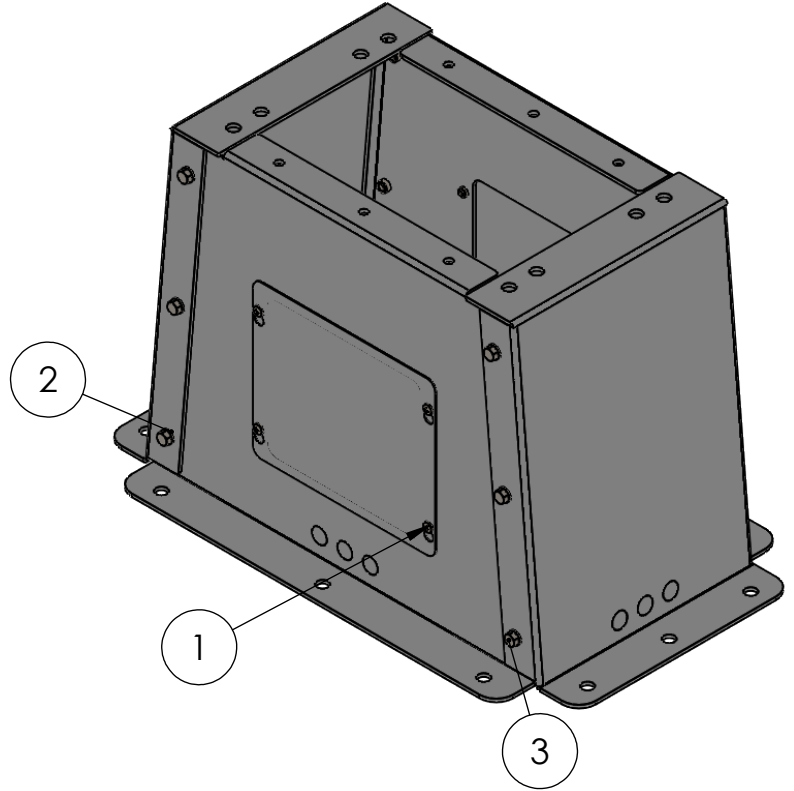
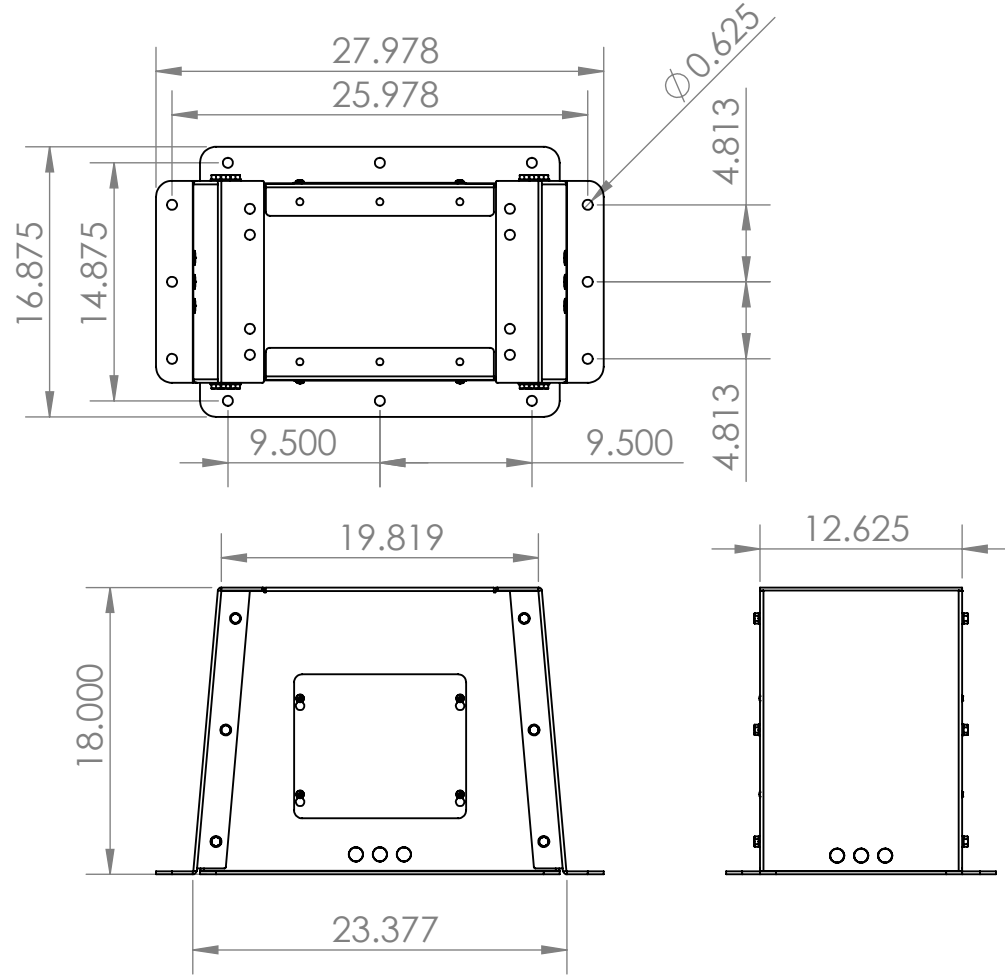

1. 1/4-20 X 1/2" long phillps screw (X8)
2. 3/8" SPlit Lock Washer (X12)
3. 3/8-16 X 1" Long Hex Bolt(X12)

A

A

Recommended
Concrete Pad
32" W X 21" L X 30" D

PROPRIETARY AND CONFIDENTIAL
THE INFORMATION CONTAINED IN THIS DRAWING IS THE SOLE PROPERTY OF <INSERT COMPANY NAME HERE>. ANY REPRODUCTION IN PART OR AS A WHOLE WITHOUT THE WRITTEN PERMISSION OF <INSERT COMPANY NAME HERE> IS PROHIBITED.

		UNLESS OTHERWISE SPECIFIED:		NAME	DATE
		DIMENSIONS ARE IN INCHES TOLERANCES: FRACTIONAL ± ANGULAR: MACH ± BEND ± TWO PLACE DECIMAL ± THREE PLACE DECIMAL ±	DRAWN		
		INTERPRET GEOMETRIC TOLERANCING PER:	CHECKED		
		MATERIAL	ENG APPR.		
		FINISH	MFG APPR.		
NEXT ASSY	USED ON		Q.A.		
			COMMENTS:		
APPLICATION		DO NOT SCALE DRAWING			

TITLE:		
SL-150 pedestal		
SIZE	DWG. NO.	REV
A		
SCALE: 1:8	WEIGHT:	SHEET 1 OF 2

2

1

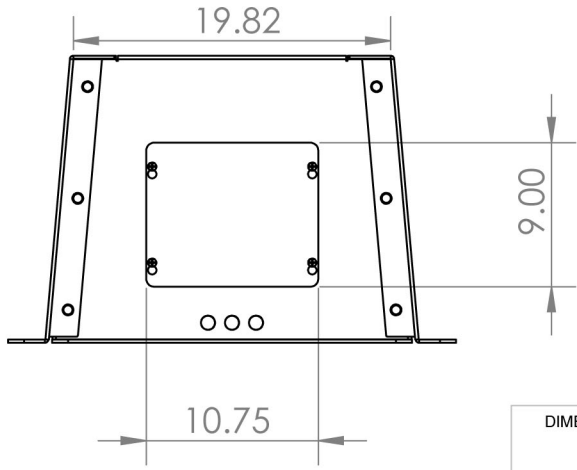
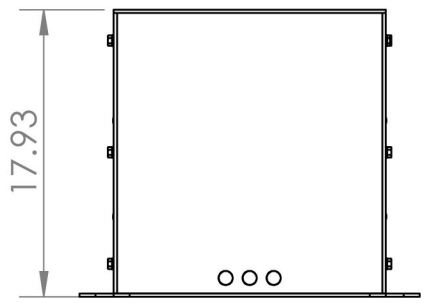
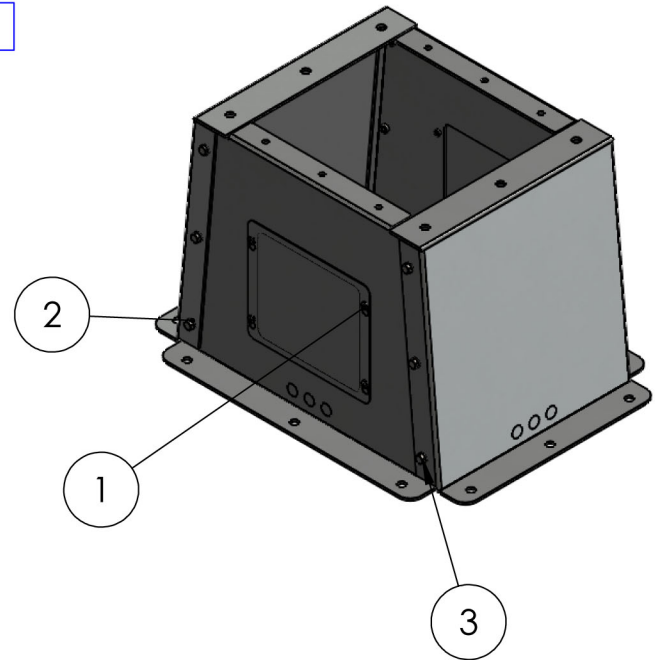
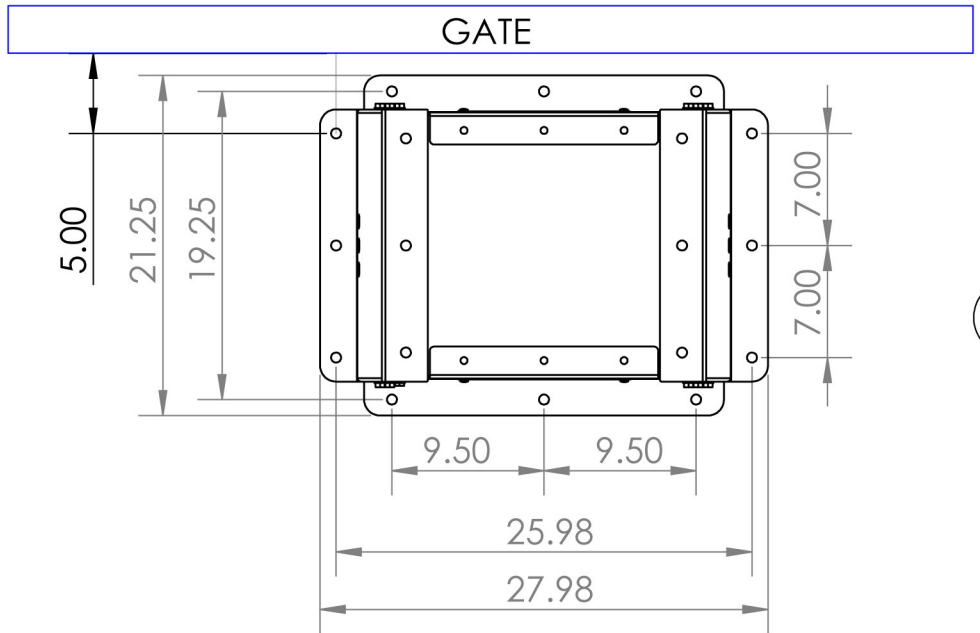

1. 1/4-20 X 1/2" long phillips screw (X8)
2. 3/8" SPlit Lock Washer (X12)
3. 3/8-16 X 1" Long Hex Bolt (X12)

Recommended Concrete Pad
32" W X 26" L X 30" D

DIMENSIONS ARE IN INCHES
DO NOT SCALE DRAWING
DRAWN BY: F. Tarula DATE DRAWN: 3/23/2021
MATERIAL: CR steel Clear zinc plated
RAW MAT:

ALL-O-MATIC, Inc.
THE INFORMATION DISCLOSED HEREIN WAS ORIGINATED BY AND IS THE PROPERTY OF ALL-O-MATIC, INC. AND ALL PATENT, PROPRIETARY, DESIGN, USE, SALE, MANUFACTURING, AND REPRODUCTION RIGHTS THERETO ARE RESERVED BY ALL-O-MATIC, INC.

CHECKED BY: DATE CHECKED:
TITLE: **SL-175 Pedestal**

SYMBOL	ECO#	ENGINEERING CHANGE ORDER REVISION DESCRIPTION	BY	CKD	DATE	SHEET 1 OF 1	SCALE: 1:12	DRAWING SIZE: A	PART#: 175-PDT
--------	------	---	----	-----	------	--------------	-------------	-----------------	----------------