

4

3

2

1

B

B

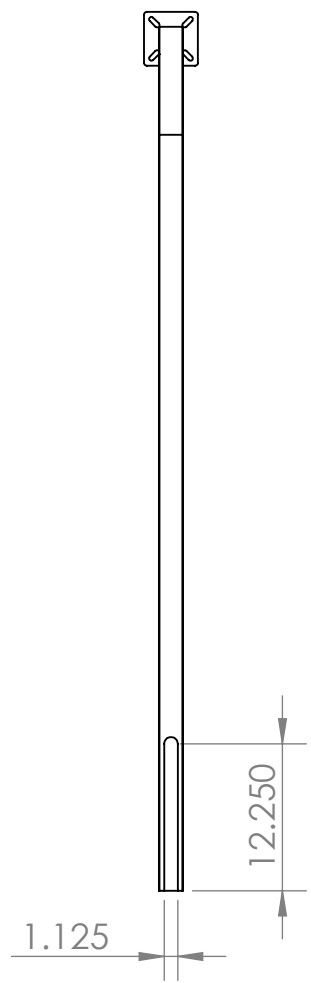
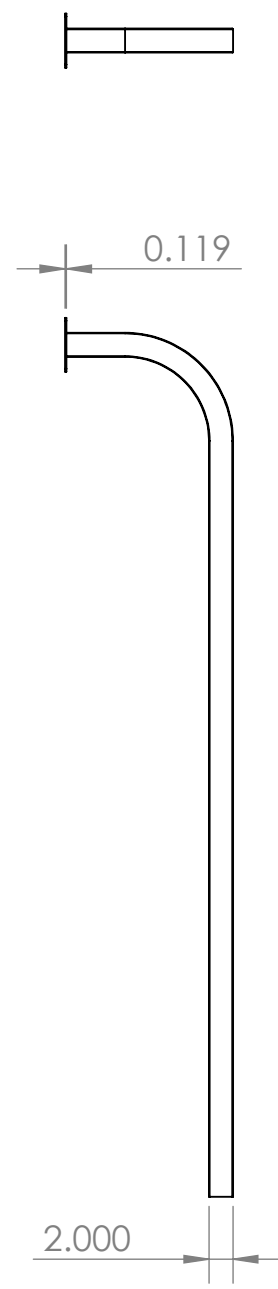

**NOTE: 50mmX50mmX3mm
Wall tubing could be used for
this part.**

PROPRIETARY AND CONFIDENTIAL
THE INFORMATION CONTAINED IN THIS
DRAWING IS THE SOLE PROPERTY OF
ALL-O-MATIC. ANY
REPRODUCTION IN PART OR AS A WHOLE
WITHOUT THE WRITTEN PERMISSION OF
ALL-O-MATIC INC. IS
PROHIBITED.

		UNLESS OTHERWISE SPECIFIED:		NAME	DATE		
		DIMENSIONS ARE IN INCHES		DRAWN	F. TARULA	2/4/19	TITLE: Inground mount goose neck_2010204
		TOLERANCES:		CHECKED			
		FRACTIONAL ±		ENG APPR.			
		ANGULAR: MACH ± BEND ±		MFG APPR.			
		TWO PLACE DECIMAL ±		Q.A.			SIZE DWG. NO. REV B AGN-GN1 1
		THREE PLACE DECIMAL ±		COMMENTS:	Very fine texture, low gloss black powder coat.		
		INTERPRET GEOMETRIC TOLERANCING PER:				SCALE: 1:16	WEIGHT:
		MATERIAL		Steel		SHEET 1 OF 1	
NEXT ASSY	USED ON	FINISH		Black Powder coat			
APPLICATION		DO NOT SCALE DRAWING					

4

3

2

1

A

A

4

3

2

1

B

B

A

A

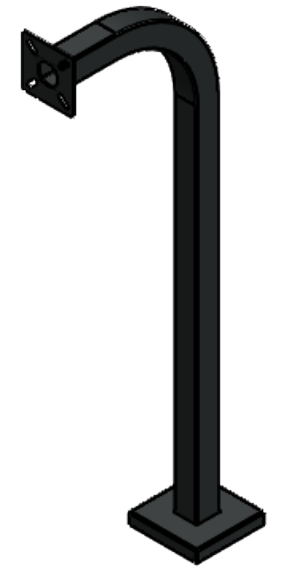
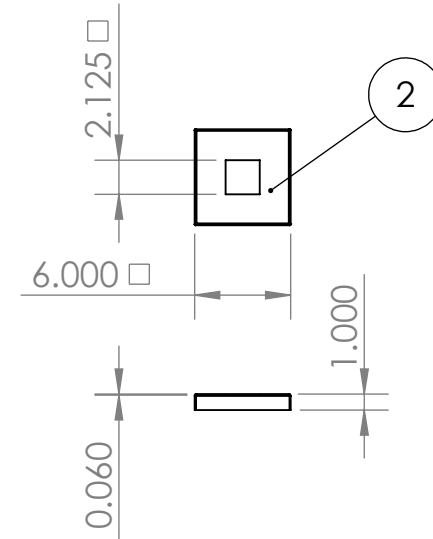
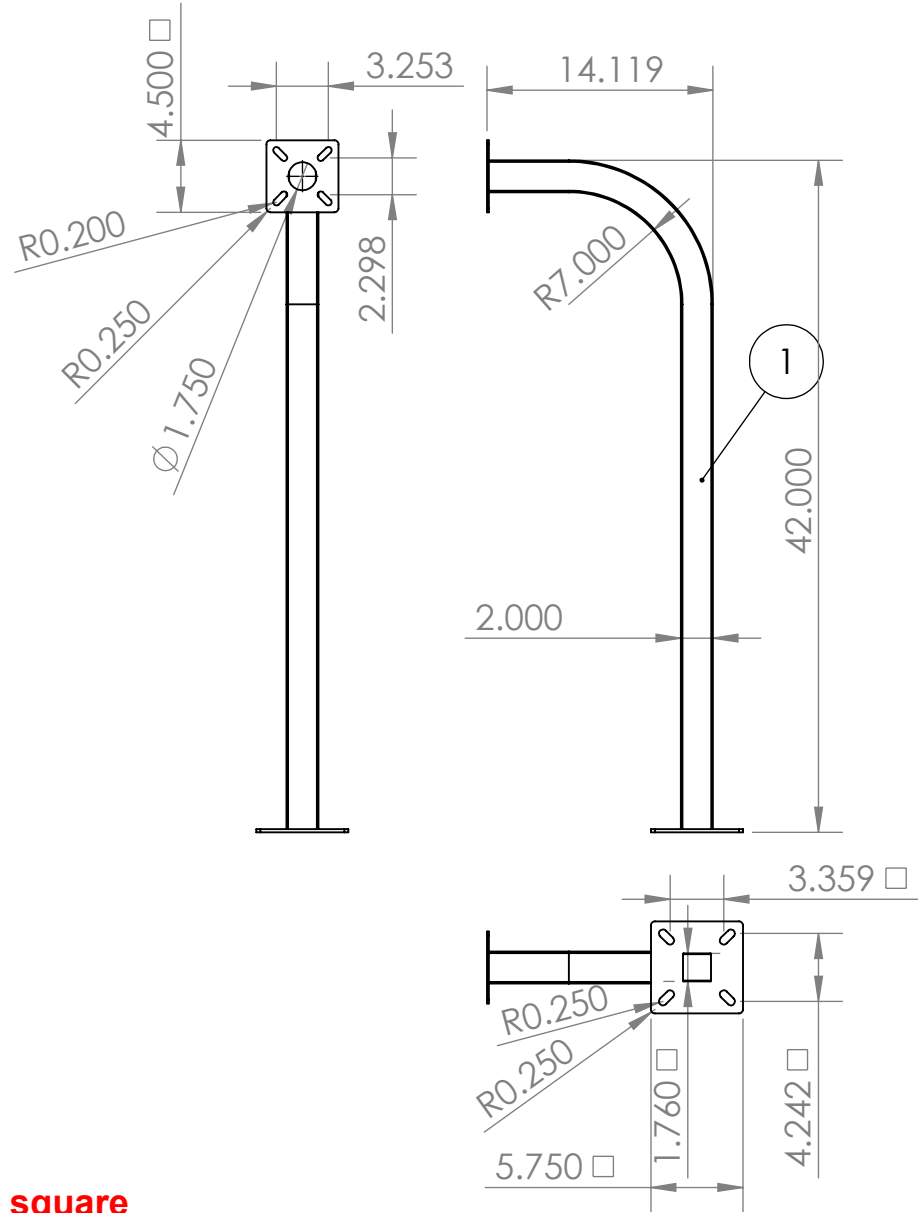
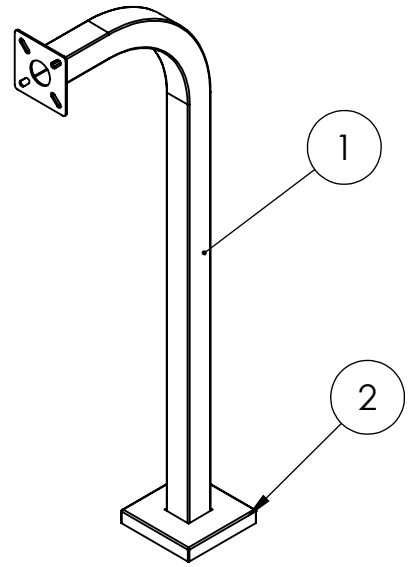

NOTE: 50mmX50mmX3mm square tubing can be used for this part.

ITEM NO.	PART NUMBER	DESCRIPTION	QTY.
1		Surface mount goose neck	1
2		Surface mount goose neck base cover	1

PROPRIETARY AND CONFIDENTIAL
 THE INFORMATION CONTAINED IN THIS DRAWING IS THE SOLE PROPERTY OF ALL-O-MATIC. ANY REPRODUCTION IN PART OR AS A WHOLE WITHOUT THE WRITTEN PERMISSION OF ALL-O-MATIC INC. IS PROHIBITED.

UNLESS OTHERWISE SPECIFIED:		NAME	DATE	TITLE:	
DIMENSIONS ARE IN INCHES		DRAWN	F. Tarula	2/4/2019	Surface mount goose neck_20190204
TOLERANCES:		CHECKED			
FRACTIONAL ±		ENG APPR.			
ANGULAR: MACH ± BEND ±		MFG APPR.			
TWO PLACE DECIMAL ±		Q.A.			SIZE DWG. NO. REV
THREE PLACE DECIMAL ±		COMMENTS:			B AGN-SM1 1
INTERPRET GEOMETRIC TOLERANCING PER:		Very fine texture, low gloss powder coating finish		SCALE: 1:12	WEIGHT: SHEET 1 OF 1
MATERIAL		Steel			
FINISH		Black Powder coat			
NEXT ASSY	USED ON	APPLICATION		DO NOT SCALE DRAWING	

4

3

2

1

