

4

3

2

1

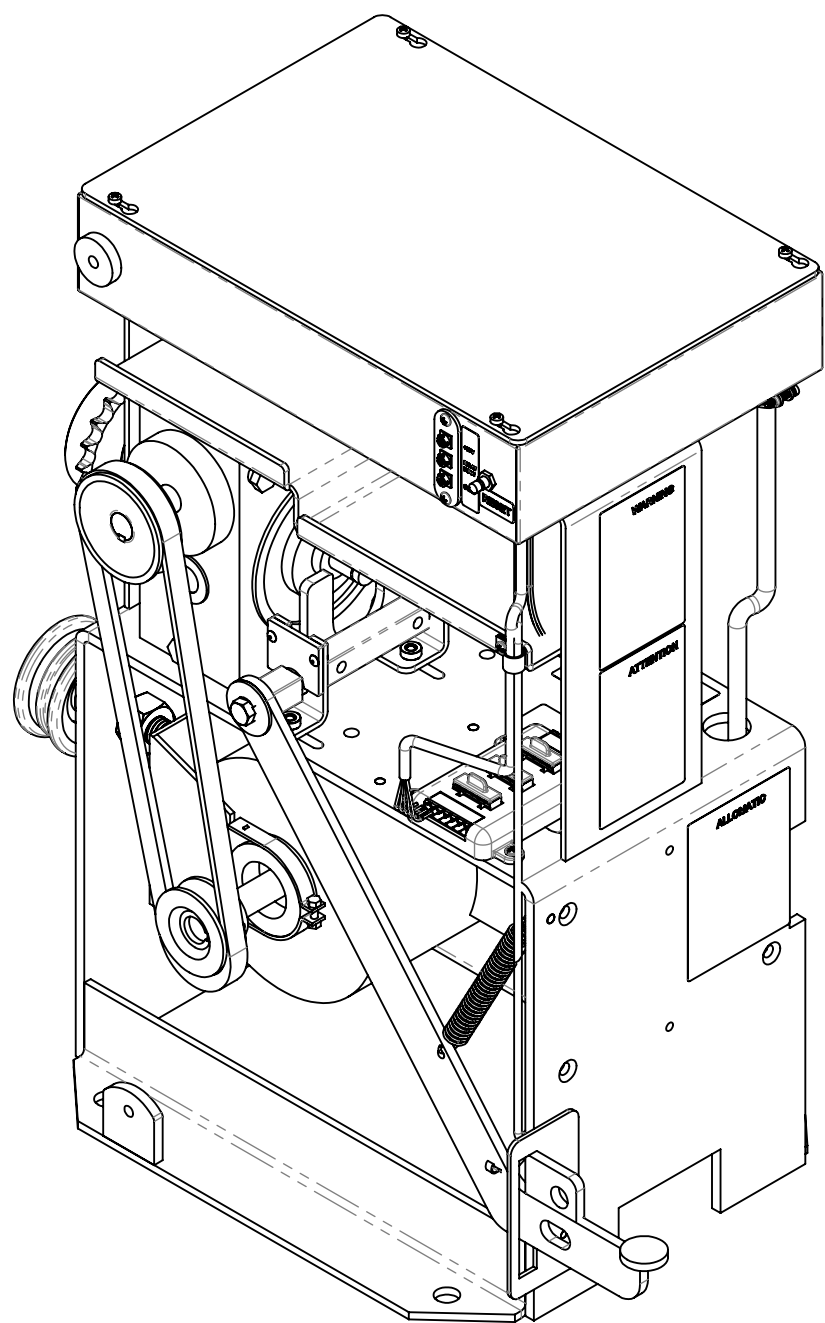
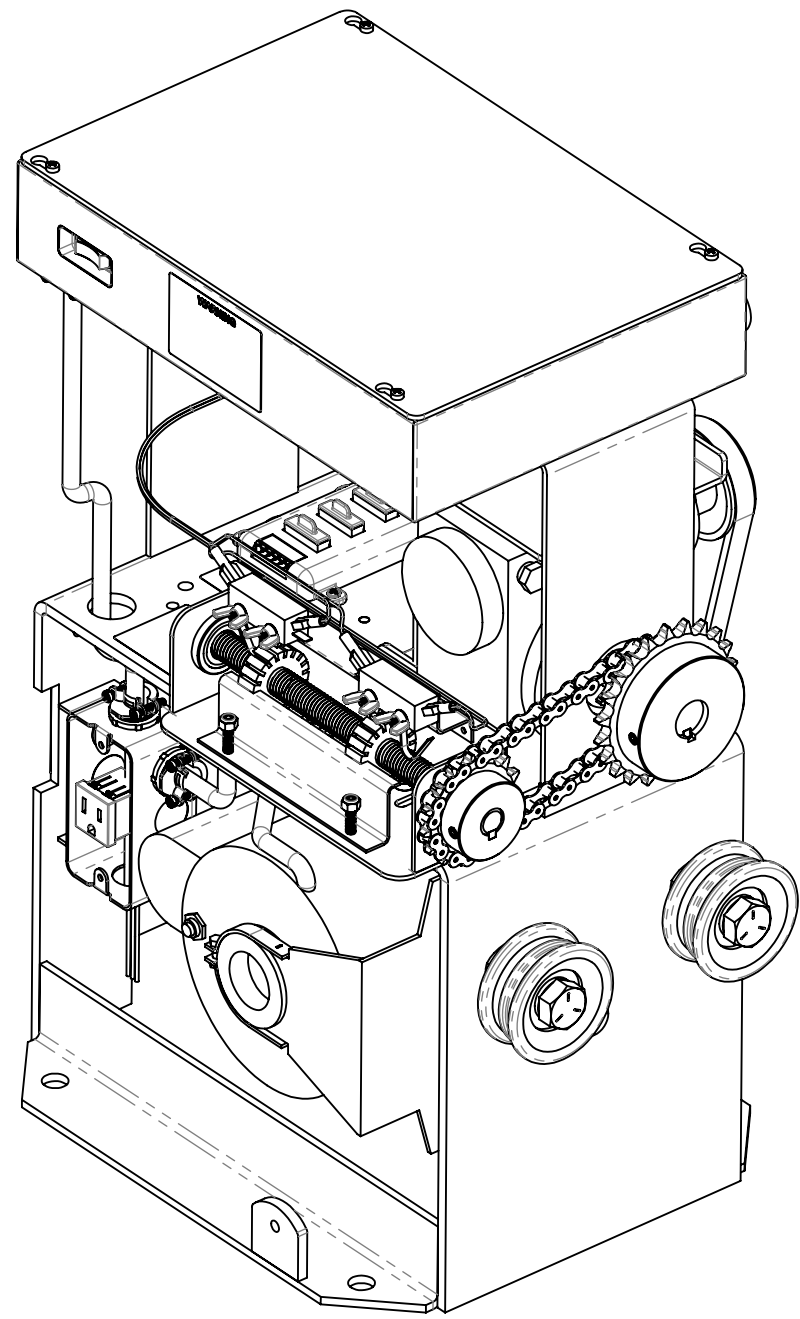
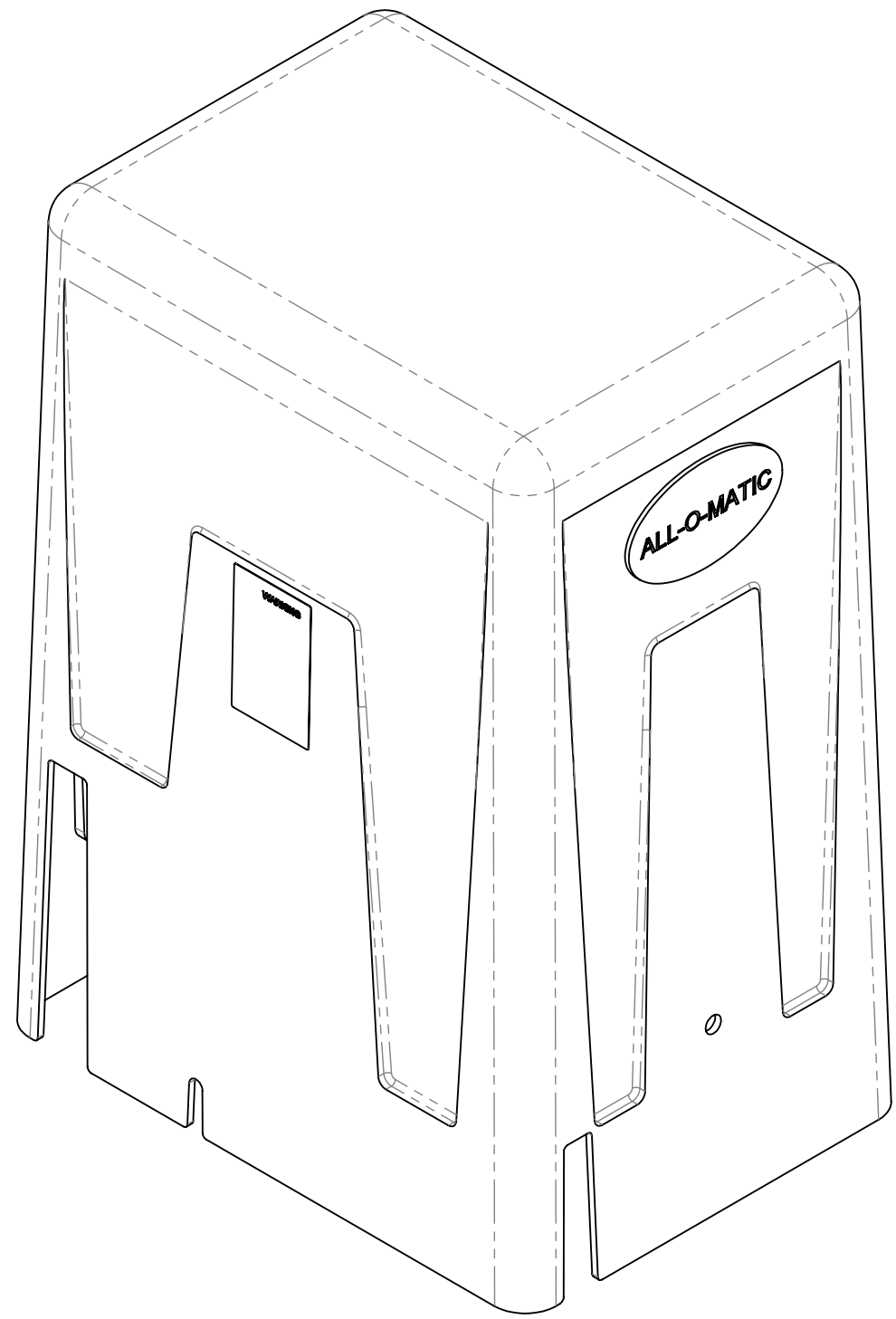

ITEM NO.	DESCRIPTION	PART NUMBER	QTY.
1	FRAME ONLY	SL-103FM	1
2	GEARBOX	GBX-101	1
3	GEARBOX PULLEY	PLY-25A	1
4	GEARBOX LIMIT SPROCKET	41B12X78	1
5	GEARBOX DRIVE SPROCKET	41B22X78	1
6	1/2 HP AC MOTOR	MTR-1050	1
7	1/2 HP AC MOTOR PULLEY	PLY-2	1
8	1/2 HP AC MOTOR BELT	4L-260 (AX24)	1
9	1/2 HP AC MOTOR WIRE HARNESS	MTR-H1050	1
10	CONTROL BOX ASSEMBLY	CBX-AY103	1
11	CONTROL BOX	CBX-103	1
12	CONTROL BOX COVER	CBC-913	1
13	CONTROL BOX RADIO RECEIVER STRIP	COM-1003	1
14	CONTROL BOX RESET PUSH BUTTON	COM-1004	1
15	CONTROL BOX ALARM BUZZER	COM-1005	1
16	CONTROL BOX ON/OFF POWER SWITCH	COM1000	1
17	CONTROL BOX 14 PIN TERMINAL STRIP	COM-1002	1
18	CONTROL BOX AC CONTROL BOARD	ACPCB-UL	1
19	LIMIT SWITCH BOX ASSEMBLY	LSB-AY103	1
20	LIMIT SHAFT SPROCKET	41B15X58	1
21	LIMIT SHAFT	LST-100	1
22	LIMIT SHAFT BEARINGS - 5/8"	BRG-6202B	2
23	LIMIT SWITCH BOX	LSB-103	1
24	LIMIT SWITCH BOX PLATE	LSP-100FP	1
25	LIMIT SWITCH BOX PLATE SPRINGS (2 PCS)	SPG-7575	2
26	LIMIT SWITCH	COM-1007	2
27	LIMIT SWITCH PLASTIC NUT	COM-1008	2
28	LIMIT SWITCH WIRE HARNESS	LSH-103	1
29	POWER SUPPLY 110VAC OUTLET	COM-1001	1
30	POWER SUPPLY WIRE HARNESS	PSH-103	1
31	FOOT PEDAL RELEASE ASSEMBLY	FPR-AY100	1
32	FOOT PEDAL RELEASE	FPR-100	1
33	FOOT PEDAL RELEASE KILL SWITCH	COM-1007P	1
34	FOOT PEDAL PAD LOCK PLATE	PLP-100FP	1
35	FOOT PEDAL HINGE PIVOT BRACKET	HPB-100FP	1
36	FOOT PEDAL HINGE BRACKET	HBK-100FP	1
37	FOOT PEDAL HINGE SPLIT BRACKET	HSB-100FP	1
38	FOOT PEDAL SPRING	SPG-100FP	1
39	FOOT PEDAL SQUARE HINGE SHAFT	SHS-100FP	1
40	LOOP RACK	LPR-2	1
41	LOOP RACK HARNESS 20"	LPR-H102	1
42	EXTERIOR PLASTIC COVER	EPC-100FP	1
43	PLASTIC CHAIN IDLER	COM-1017	2
44	CHAIN BRACKET	COM-1009	2
45	CHAIN BOLT	COM-1010-1	2

ALL-O-MATIC, Inc.
 7820 Gloria Ave. Phone: (818) 787-1988
 Van Nuys CA, USA 91406
 EMAIL: fortino@allomatic.net

DIMENSIONS ARE IN INCHES
 BREAK SHARP EDGES 10-40
 MACHINED SURFACE FINISH IS
 1.6 MICROMETERS
 DO NOT SCALE DRAWING

THE INFORMATION DISCLOSED HEREIN WAS ORIGINATED BY
 AND IS THE PROPERTY OF ALL-O-MATIC, INC. AND ALL PATENT,
 PROPRIETARY, DESIGN, USE, SALE, MANUFACTURING, AND
 REPRODUCTION RIGHTS THERETO ARE RESERVED BY
 ALL-O-MATIC, INC.

DRAWN BY: S. HUERTA DATE: 09/23/2021 CHECKED BY: X DATE CHECKED: X
 MATERIAL: RAW MAT:

TITLE: **SL-100FP AC**
 SHEET 1 OF 2 SCALE: 1:4 DRAWING SIZE: C PART#: **SL-100FP AC**

SYMBOL	ECO#	PROTOTYPE	ENGINEERING CHANGE ORDER REVISION DESCRIPTION	BY	CKD	DATE

4

3

2

1

