

ITEM NO.	DESCRIPTION	PART NUMBER	QTY.
1	FRAME ONLY	SW-350FM	1
2	GEARBOX	GBX-350	1
3	GEARBOX DRIVE SPROCKET	50B11TX1	1
4	GEARBOX PULLEY	PLY-7	1
5	1/2 HP BRUSHLESS DC MOTOR	MTR-1500	1
6	1/2 HP BRUSHLESS DC MOTOR BRACKET	MTR-350B	1
7	1 HP BRUSHLESS DC MOTOR BRACKET	MTR-351B	1
8	1/2 HP BRUSHLESS DC MOTOR PULLEY	PLY-2	1
9	BELT	4L-360 (AX34)	1
10	1 HP BRUSHLESS DC MOTOR	MTR-1750	1
11	CONTROL BOX ASSEMBLY	CBX-AY350	1
12	CONTROL BOX	CBX-350	1
13	CONTROL BOX COVER	CBC-913	1
14	CONTROL BOX DC CONTROL BOARD - 1/2 HP	BLDC-JULPCB	1
15	CONTROL BOX DC CONTROL BOARD - 1 HP	BLDC-JULPCB1	1
16	CONTROL BOX ALARM BUZZER	COM-1005	1
17	CONTROL BOX RADIO RECEIVER STRIP	COM-1003	1
18	CONTROL BOX RESET PUSH BUTTON	COM-1004	1
19	CONTROL BOX BRIDGE RECTIFIER	COM-1006	1
20	POWER SUPPLY BOX LINE-IN WIRE HARNESS	COM-1016	1
21	POWER SUPPLY BOX ON/OFF SWITCH	COM-1000	2
22	BATTERY WIRE HARNESS	BTY-H350	1
23	LIMIT SWITCH ASSEMBLY	LSA-AY350	1
24	LIMIT SWITCH	COM-1007	2
25	LIMIT SWITCH COLLAR	COM-1012	2
26	LIMIT SWITCH WIRE HARNESS	LSH-350	1
27	LIMIT SWITCH MOUNT BRACKET	LSB-350	1
28	POWER SUPPLY BOX ASSEMBLY	PSB-AY350	1
29	POWER SUPPLY BOX	PSB-350	1
30	POWER SUPPLY BOX COVER	PSC-350	1
31	POWER SUPPLY BOX TRANSFORMER	TFR-480	1
32	POWER SUPPLY BOARD	EMI-PCB	1
33	POWER SUPPLY WIRE HARNESS	PSH-350	1
34	POWER SUPPLY BOX 110VAC OUTLET	COM-1001	1
35	BATTERY BOX ASSEMBLY	BTB-AY350	1
36	BATTERY BOX	BTB-350	1
37	7AH BATTERY	BTY-1270	2
38	BATTERY BOX COVER	BTC-350	1
39	DRIVE SHAFT ASSEMBLY	DST-AY350	1
40	DRIVE SHAFT	DST-350	1
41	DRIVE SHAFT BEARING	BRG-207F	2
42	DRIVE SHAFT SPROCKET	50BC44-125	1
43	DRIVE SHAFT SPROCKET CLUTCH W/SQUARE	DCL-350	1
44	MAIN DRIVE SHAFT SPRING	SPG-350	1
45	DRIVE SHAFT SPROCKET CHAIN	50NPX335	1
46	LOOP RACK	LPR-2	1
47	LOOP RACK WIRE HARNESS	LPR-H350	1
48	EXTERIOR PLASTIC COVER	EPC-350	1
49	EXTERIOR PLASTIC HUB COVER	EPC-S300	1
50	SWINGER HUB	COM-1011	1
51	FOOT PEDAL RELEASE	FPR-AY350	1
52	EXTERIOR COVER TAB	ETC-350	1

**ALL-O-MATIC, Inc.**  
 7820 Gloria Ave. Phone: (818) 787-1988  
 Van Nuys CA, USA 91406  
 EMAIL: fortino@allomatic.net

DIMENSIONS ARE IN INCHES  
 BREAK SHARP EDGES 10-40  
 MACHINED SURFACE FINISH IS  
 16 MICROMETERS  
 DO NOT SCALE DRAWING

THE INFORMATION DISCLOSED HEREIN WAS ORIGINATED BY  
 AND IS THE PROPERTY OF ALL-O-MATIC, INC. AND ALL PATENT,  
 PROPRIETARY DESIGN, USE, SALE, MANUFACTURING, AND  
 REPRODUCTION RIGHTS THEREIN ARE RESERVED BY  
 ALL-O-MATIC, INC.

DRAWN BY: S. HUERTA DATE: 03/01/2022 CHECKED BY: F. TARULA DATE: [ ]  
 MATERIAL: N/A  
 RAW MAT: N/A

TITLE: **SW-350DC**  
 SHEET 1 OF 2 SCALE: 1:4 DRAWING SIZE: C PART#: SW-350DC

4

3

2

1

**POWER SUBPLY BOX ASSEMBLY: PSB-AY350** (28)

**BATTERY BOX ASSEMBLY: BTB-AY350** (35)

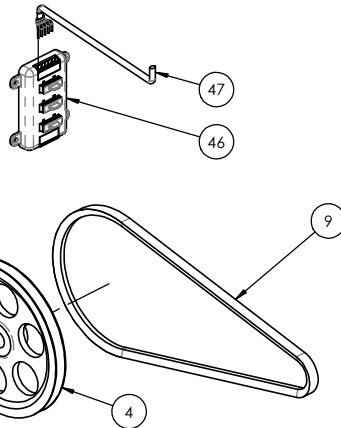
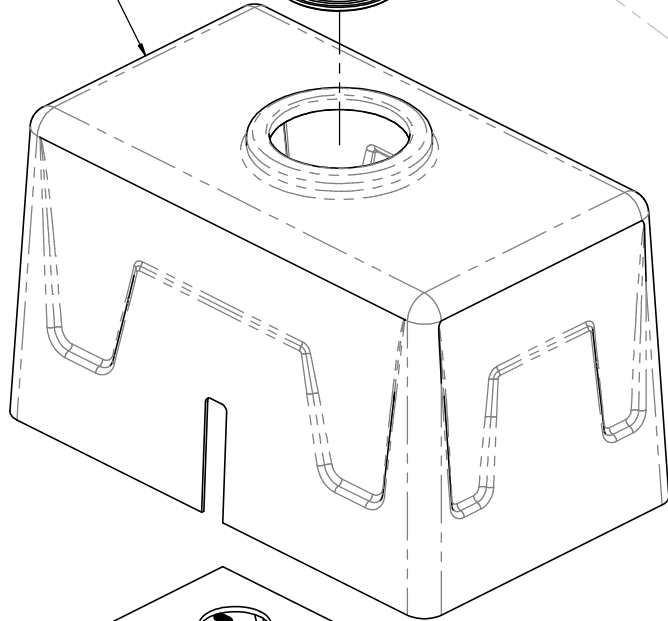
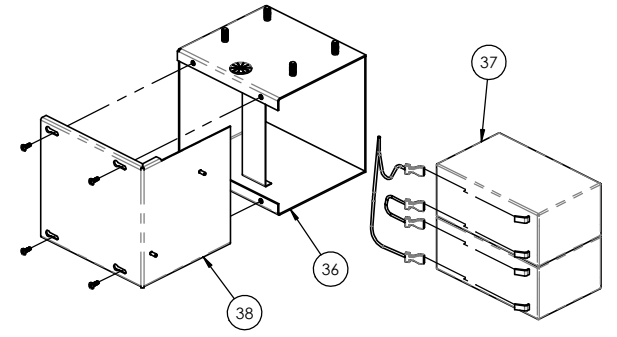
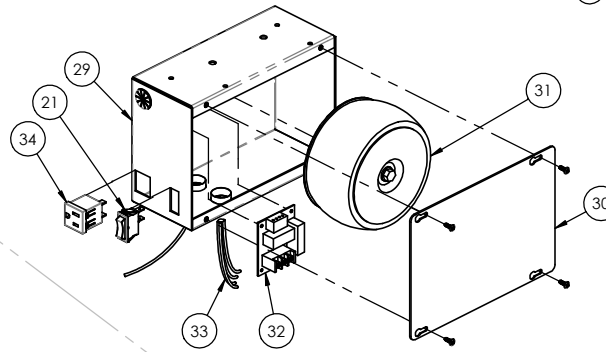
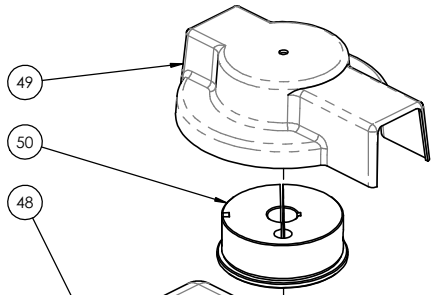

**LIMIT SWITCH ASSEMBLY: LSA-AY350** (23)

**DRIVE SHAFT ASSEMBLY: DST-AY350** (39)

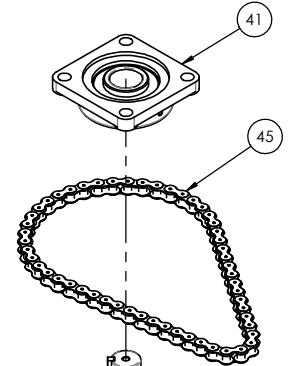
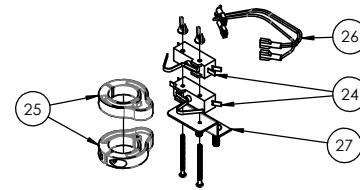

**CONTROL BOX ASSEMBLY: CBX-AY350** (11)

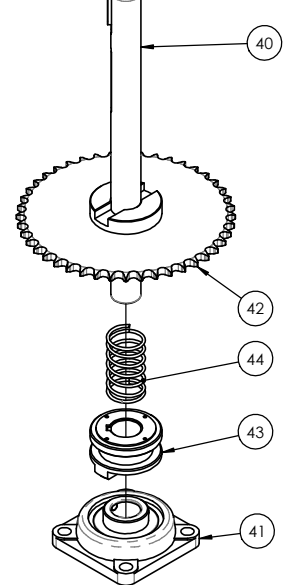
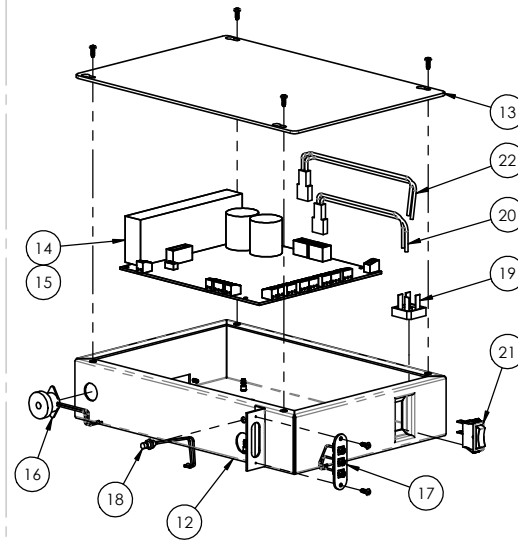
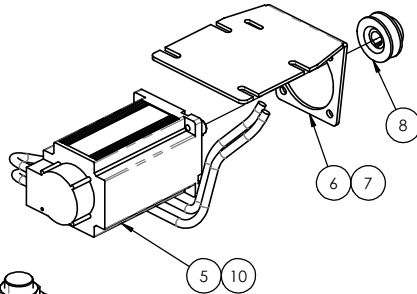
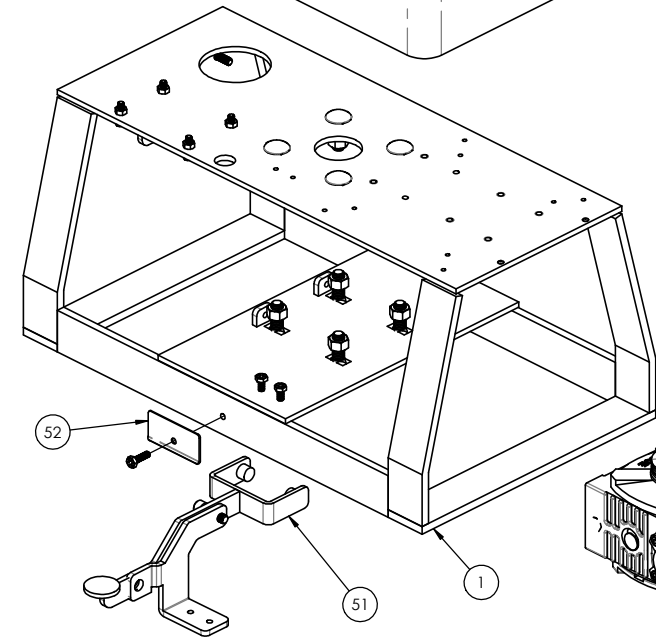

4

3

2

1